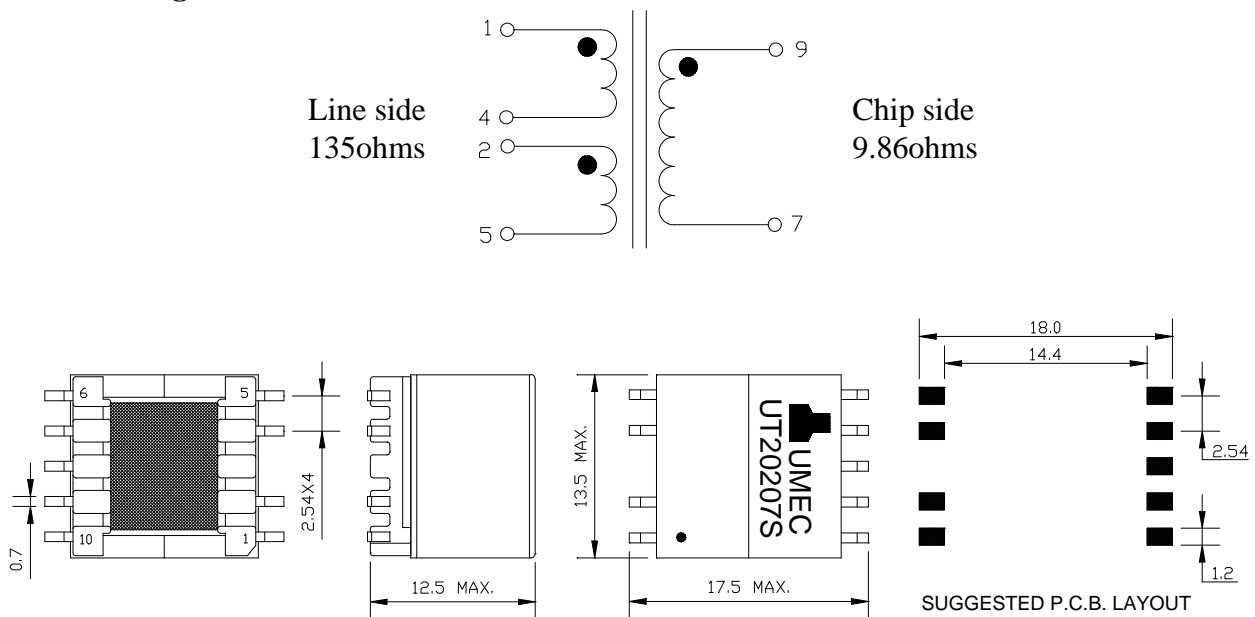

UM PART NO.:	SPECIFICATIONS	REV.	
UT20207S	SDSL Transformer	A1	2001/11

Electrical specification at 25⁰C:

- 1.) Turns Ratio and Polarity : 3.7CS : 1±2% , Line Side to Chip Side .
- 2.) D.C.R : 2.0Ω max . , PIN(1-5) , PIN(4-2) shorted.
: 1.0Ω max . , PIN(9-7).
- 3.) Line side Inductance : 3.0mH±6% , at 10KHz 100mV, PIN(1-5) ; PIN(4-2) shorted .
- 4.) DC. Current : 100mA max .
- 5.) Leakage Inductance : 17uH max. , at 100KHz 100mV, PIN(1-5) ; PIN(4-2)&PIN(9-7) shorted.
- 6.) Insertion Loss : 0.5dB max. , at 40KHz .
- 7.) Return Loss : 16.0dB min. , 40KHz to 300KHz .
- 8.) Longitudinal Balance : 50dB min. , 40KHz to 300KHz .
- 9.) Total Harmonic Distortion : -80dB max. , at 20KHz 4.5Vpp .
- 10.) HI-pot test : 1500Vac 60s or 1875Vac 2s , Line side to Chip side .
- 11.) Operating Temperature : -40⁰C to +85⁰C

Note: the transformer meets the specifications for supplementary insulation per IEC 950 with working voltage of 250V.

Schematic diagram & Dimension:

NOTE: Specifications are subject to change without prior notice.

UNIT : mm

Tolerances : ±0.2mm

E10-032-B